



# 24-C Canyon AT4X AEV

## Nylon Mud Flap Set, 5/8" Offset, Front

### Mounting Diagram & Instructions

Kit# GCN221F

#### IMPORTANT:

**Manufacturer is not responsible for negligent use of vehicle with mud flaps installed, including over-tightening of screws and bolts causing damage to vehicle or mud flaps.**



#### TOOLS REQUIRED-

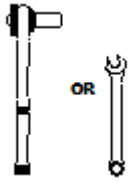

1/2" Open Wrench or  
Socket Wrench

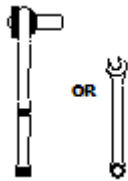

1/4" Open Wrench or  
Socket Wrench

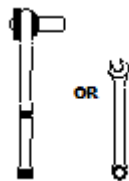

7/16" Open Wrench or  
Socket Wrench



T15 Torx  
Bit

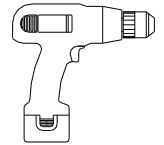

Electric or Rechargeable  
Drill

#### FLAPS

(1) Upper Mount  
Front, DS  
Part #771310

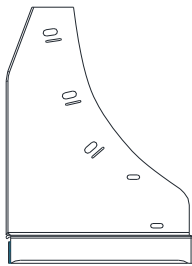

(1) Upper Mount  
Front, PS  
Part #771311

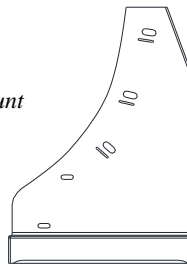

(2) Rubber Flap  
Universal  
12" x 8-3/4"

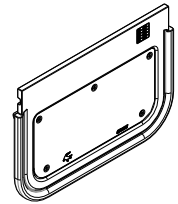

(1) Nylon Cap  
Driver Side  
Part #080642  
(Assembled on Upper Mount)

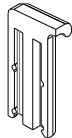

(1) Nylon Cap  
Passenger Side  
Part #080643  
(Assembled on Upper Mount)

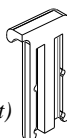

(1) Bracket  
Driver Side  
Part #771218

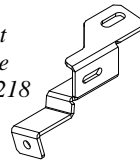

(1) Bracket  
Passenger Side  
Part #771219

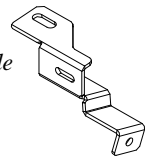

#### PARTS BAG # 771314

a) (6) Capscrew  
1/4"-20 x 5/8", SS, ox.  
Part #014071

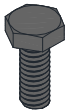

b) (2) Capscrew  
1/4"-20 x 1" SS, ox.  
Part #014073



c) (2) Screw, Sheet Metal, Blk Ox.  
1/4" Hex Washer Head, #8-18x1"  
Part # 016055



d) (4) Spacer Washer, HDPE  
5/16" x 1" x 1/4"  
Part #018036

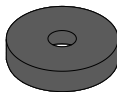

e) (10) Washer, Flat  
0.281" x 1", SS, oxid  
Part #018069

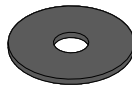

f) (2) Washer, Flat  
0.203" x 1", SS, oxid.  
Part #018070

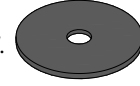

g) (2) Washer, Lock  
1/4"-20, Stainless  
Part #024000



h) (2) Nut, Hex  
1/4"-20, Stainless  
Part #025000



i) (4) Washer, Nylon  
0.281" x 1"  
Part #054084



j) (4) Spacer Washer, HDPE  
7/16" x 1" x 1/4"  
Part #054091



k) (2) Universal J-clamp  
1.5" x 2.5" Anodized  
Part #767417

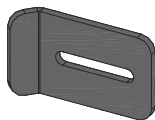

l) (3) Mud Flap Clip  
Driver Side  
Part # 769312

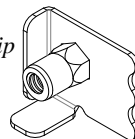

m) (3) Mud Flap Clip  
Passenger Side  
Part #769313

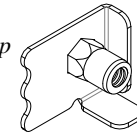

## MUD FLAPS:

Before you install your Mud Flap Set, see the parts list for all necessary parts. Start on the driver's side.

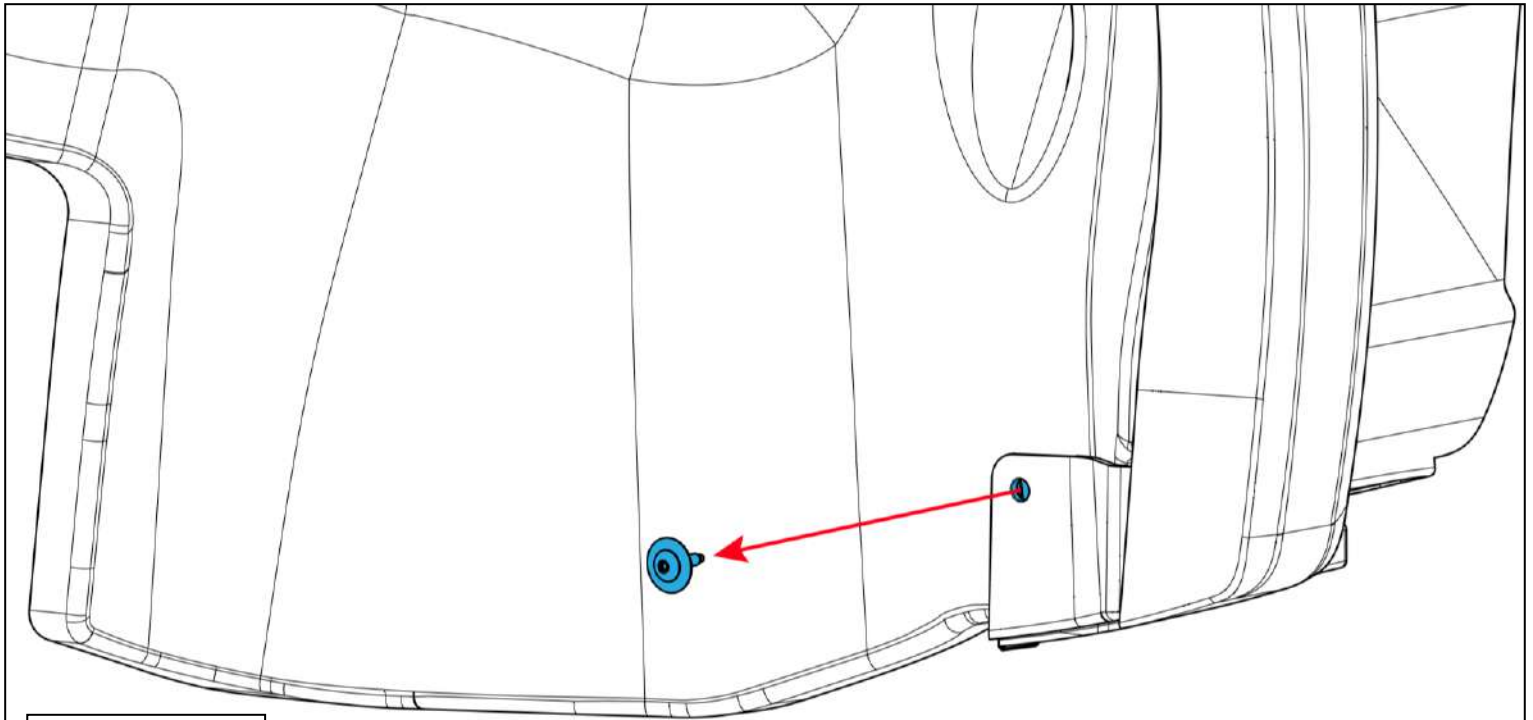

Driver's Side

1-1 Remove the factory screw from the wheel well, as shown.

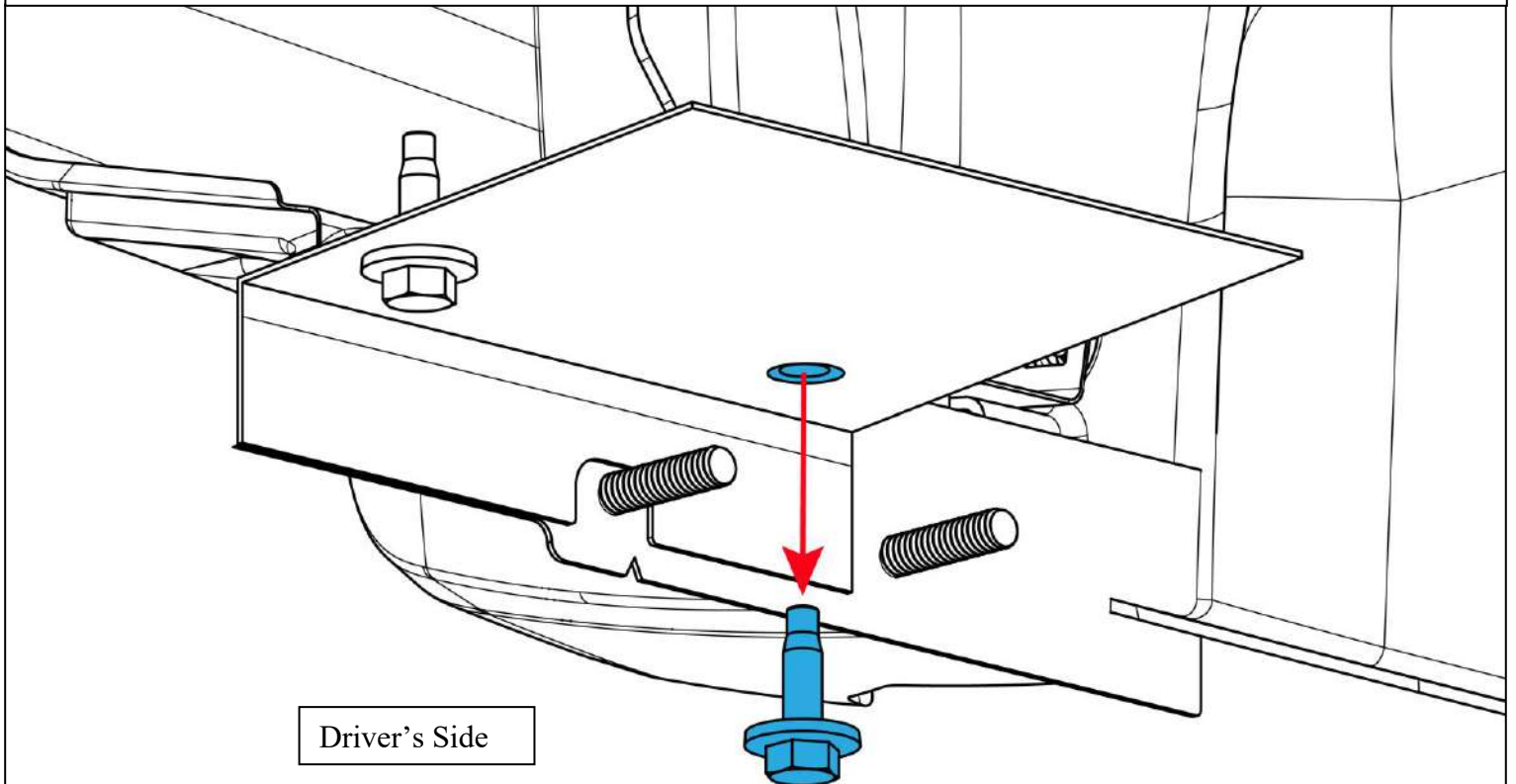

Driver's Side

2-1 Remove the factory screw from the underside of the wheel well, as shown.

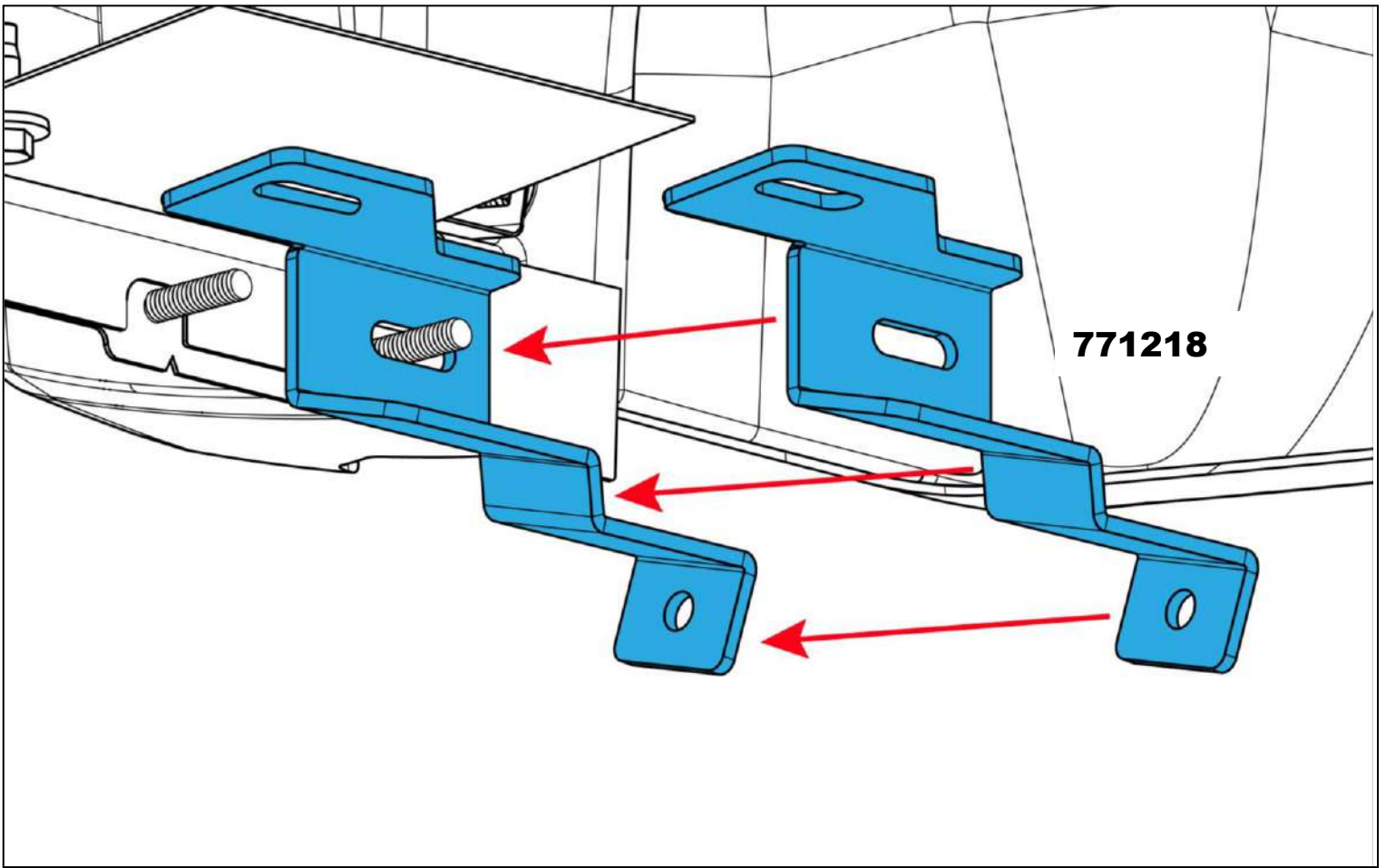

2-2 Install bracket as shown.

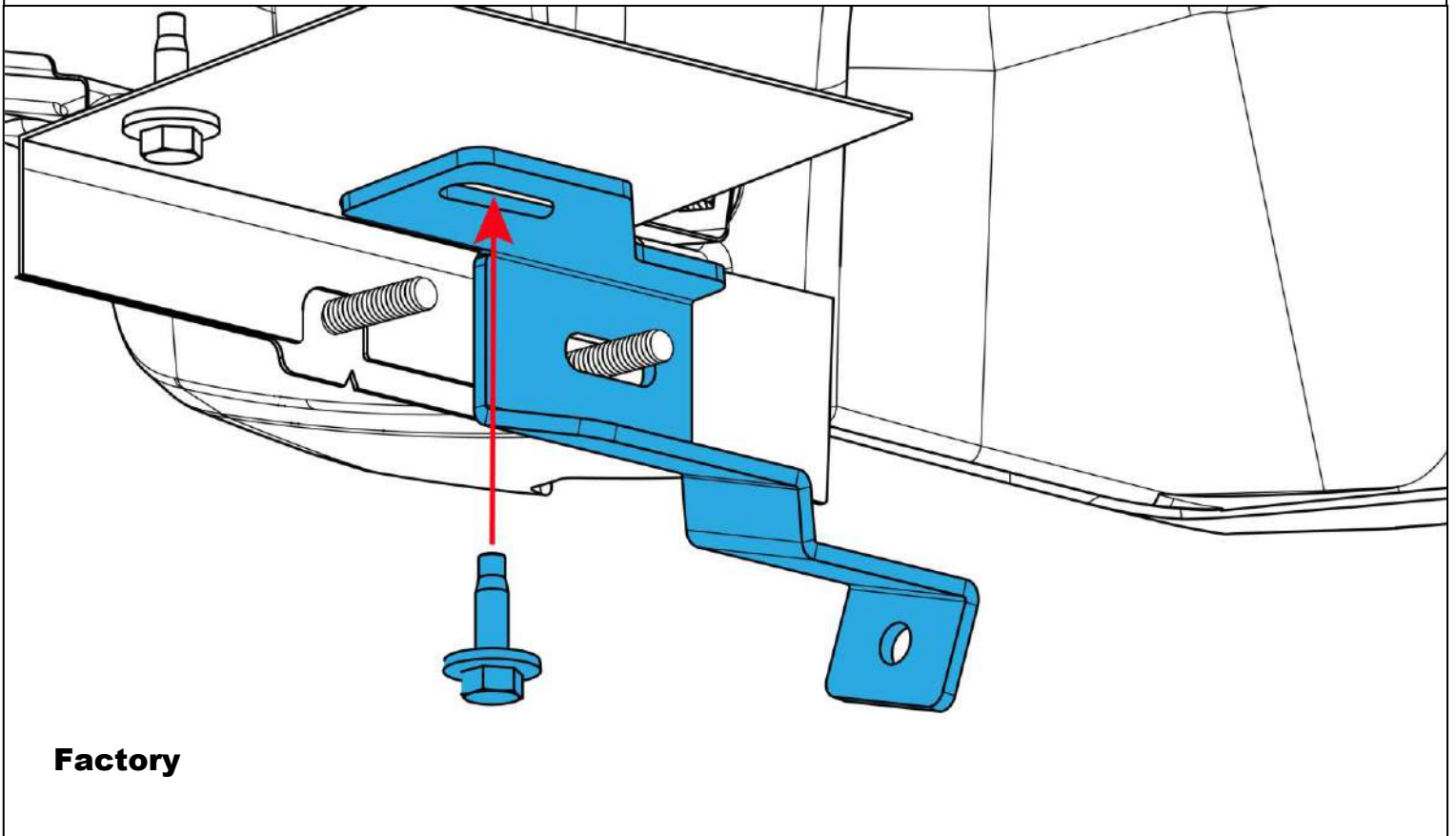

2-3 Reinstall factory screw as shown.

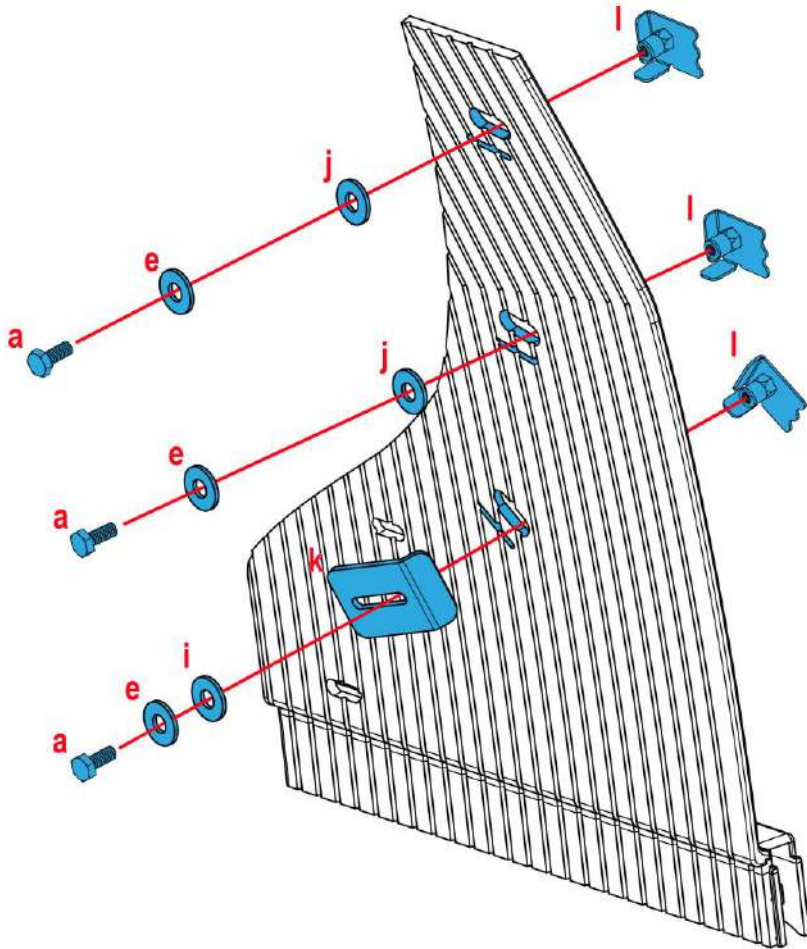

3-1 Loosely install mount clips (l) on mudflap holes #1 to #3 as shown.

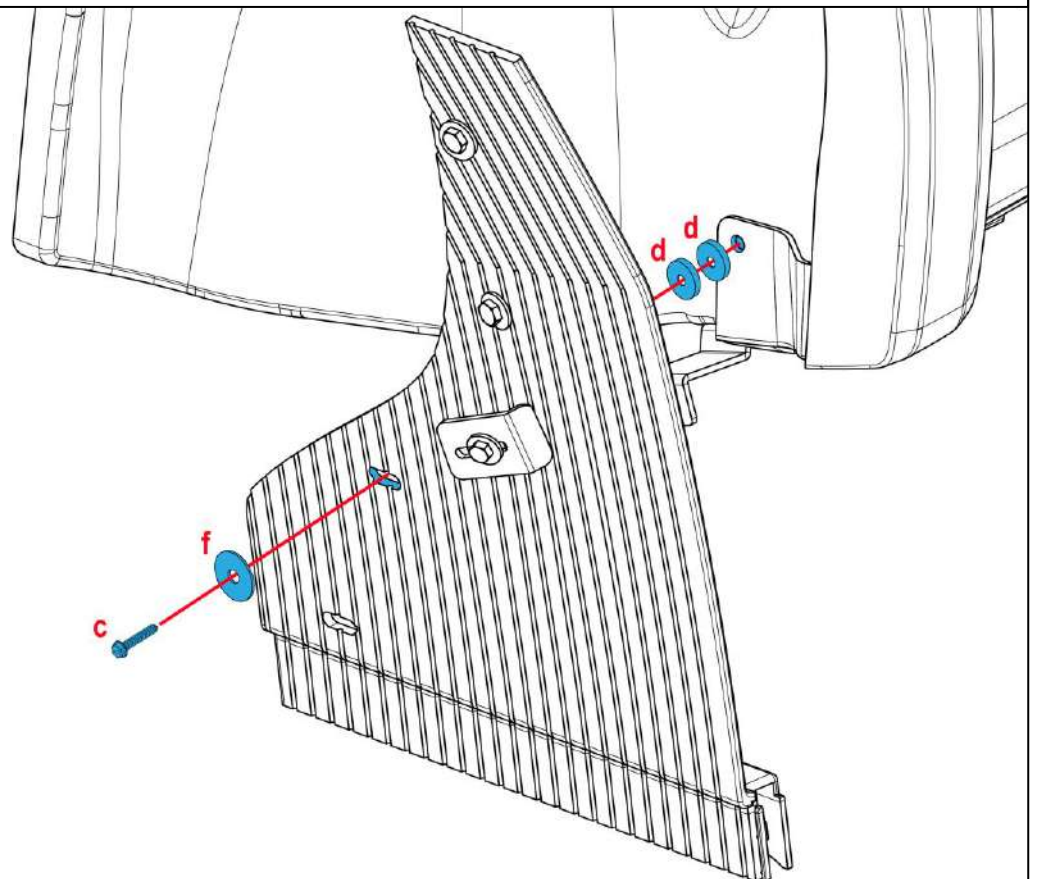

4-1. Install mud flap hole #4 to factory hole as shown.

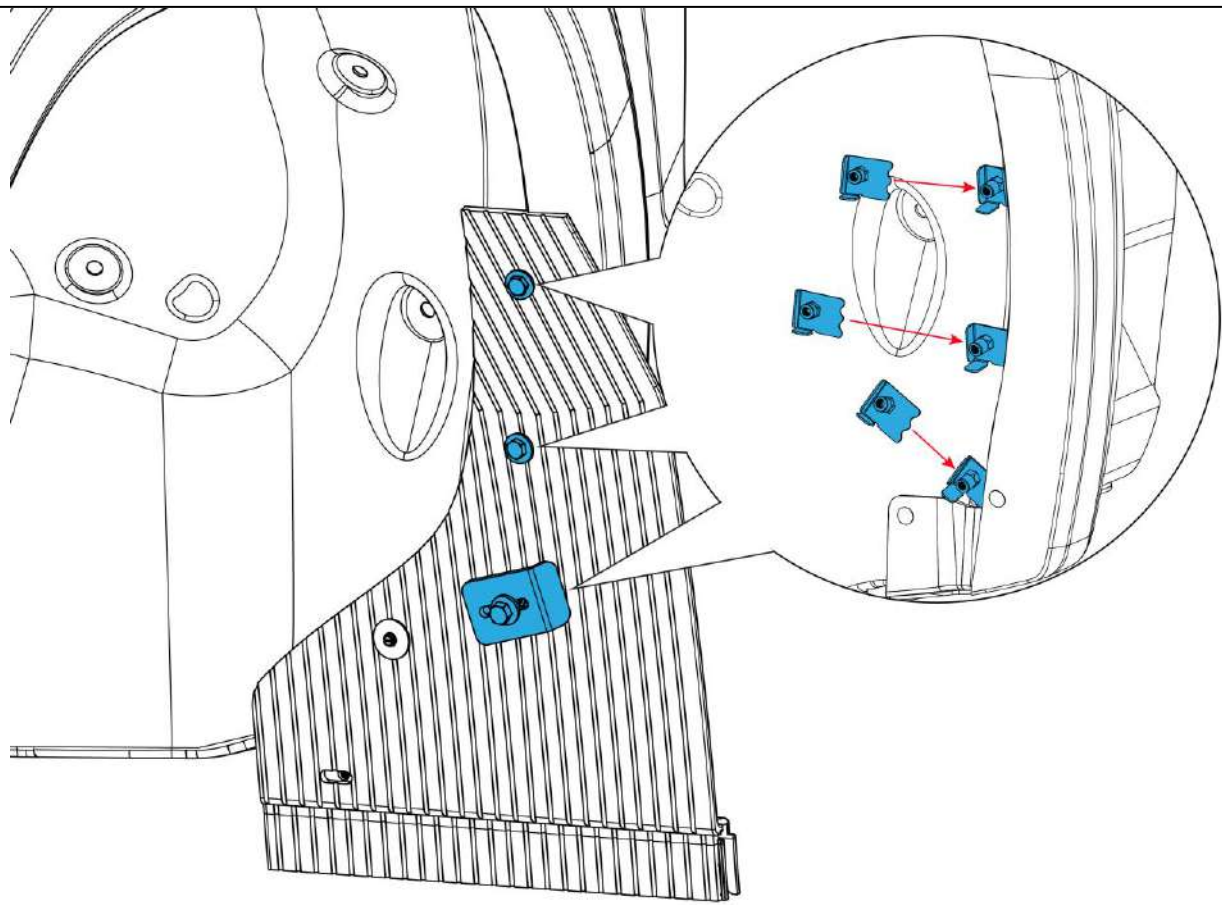

5-1 Slide mount clips behind the fender lip and loosely secure

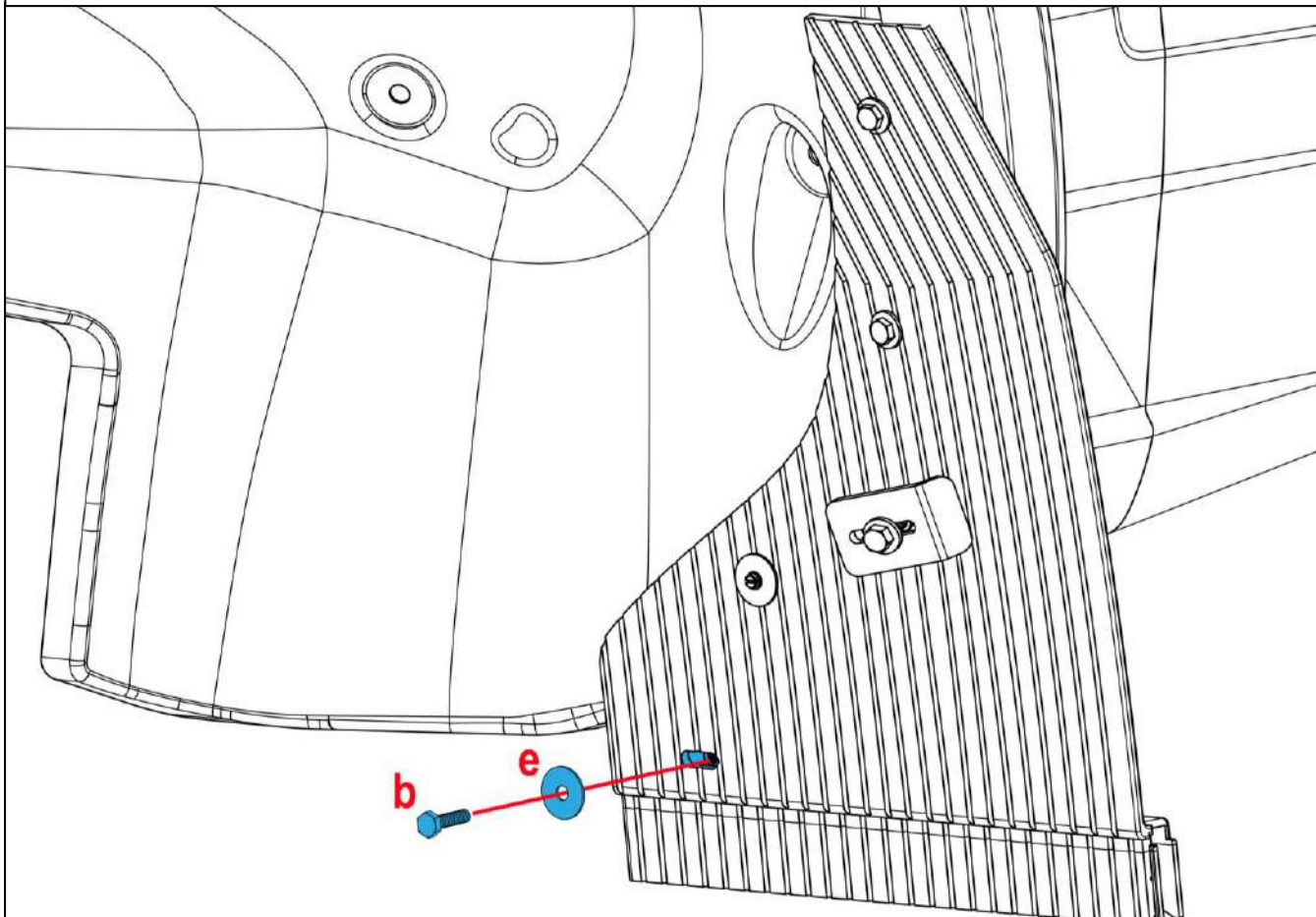

6-1 Install mudflap hole #5 to bracket as shown.

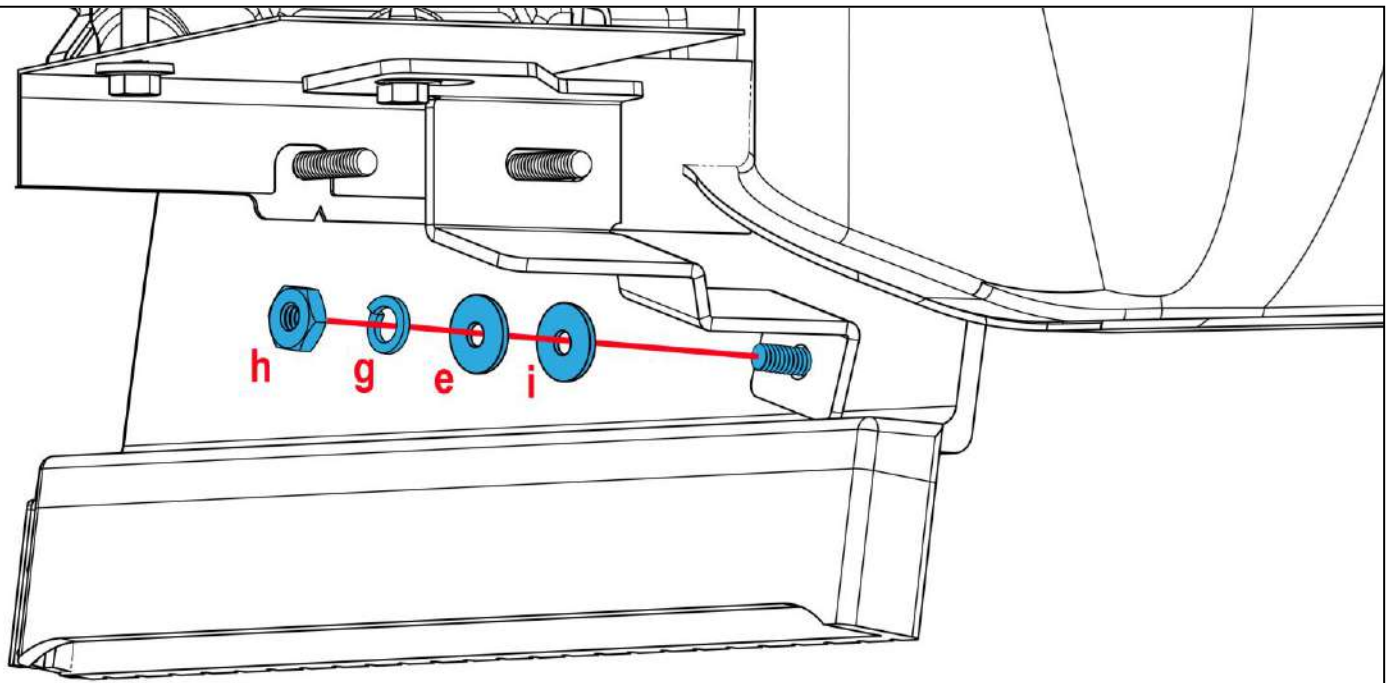

6-2 Secure hardware installed in step 6-1 as shown.

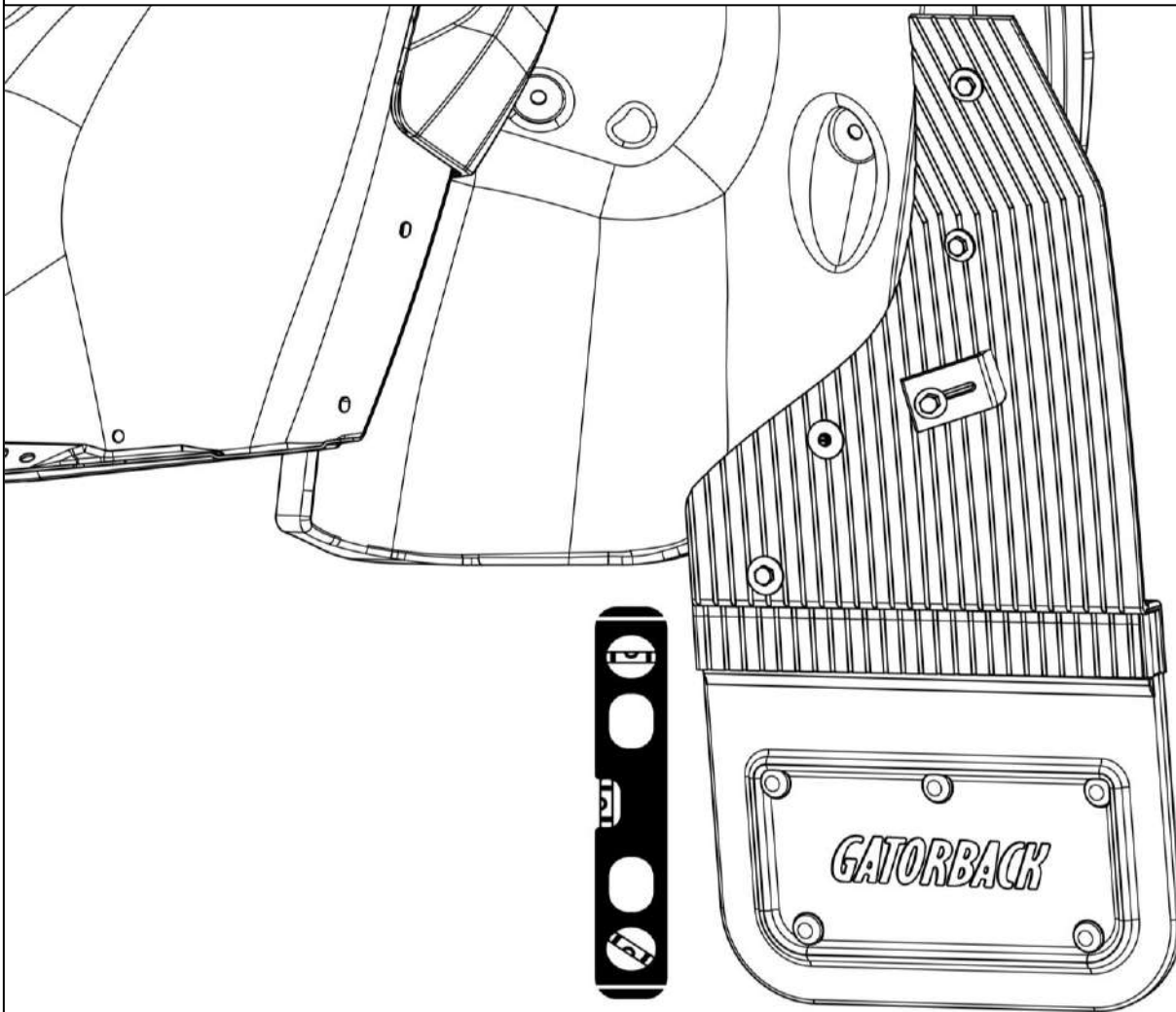

7-1 Using a bubble level or other levelling tool, ensure that the mud flap is level. Tighten fasteners. Be sure to align the u-clamps so they are adding pressure to hold the mud flap tight against the wheel well.

Repeat procedure for passenger side.

### ASSEMBLY OF NYLON MUD FLAPS:

1. Remove locking caps from nylon upper mounts and set aside for reinstallation.
2. Remove and discard the plastic strip inside the track at the bottom of the nylon upper mount.
3. Slide rubber guide into track of nylon upper mount.
4. Reinstall locking cap(s) on bottom of nylon upper mount.  
**Note: To fully lock this cap into place, you should hear two clicks.** When the cap is fully locked, it will be even with the offset part of the upper mount.
5. Repeat Procedure for second mud flap.

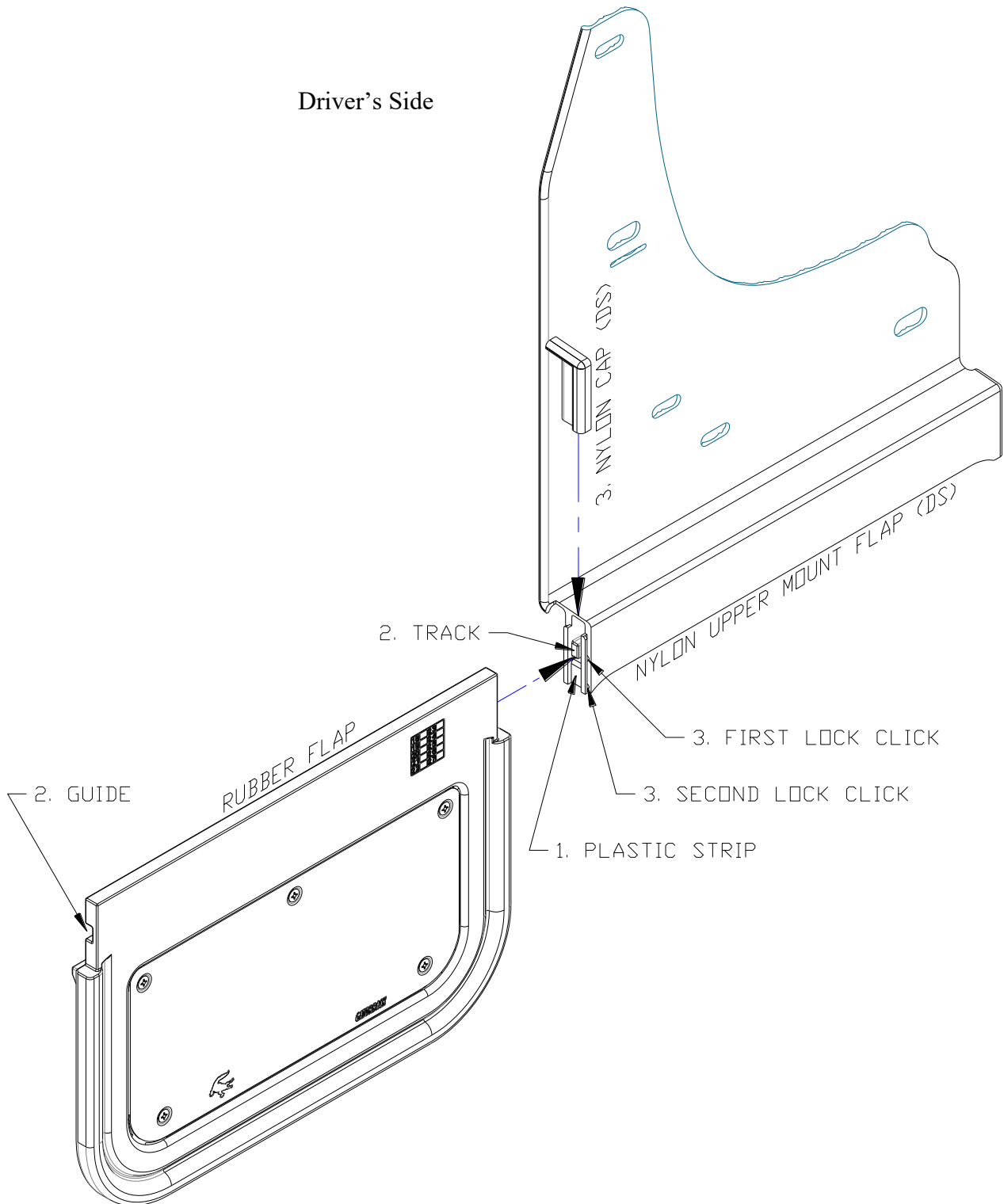

Please check out our YouTube channel to see an install video for this application.



**IMPORTANT:**

**Manufacturer is not responsible for negligent use of vehicle with mud flaps installed, including over-tightening of screws and bolts causing damage to vehicle or mud flaps.**



**TOOLS REQUIRED-**

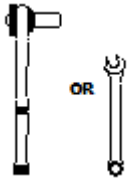

1/4" Open Wrench or  
Socket Wrench

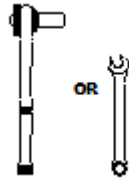

7/16" Open Wrench or  
Socket Wrench



T15 Torx  
Bit

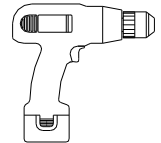

Electric or Rechargeable  
Drill

**FLAPS**

(1) Upper Mount  
Rear, DS  
Part #771312

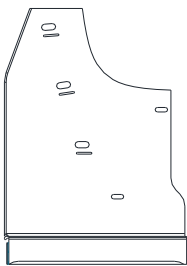

(1) Upper Mount  
Rear, PS  
Part #771313



(2) Rubber Flap  
Universal  
12" x 10-3/4"

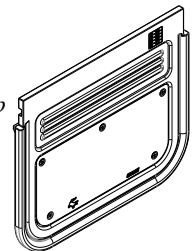

(1) Nylon Cap  
Driver Side  
Part #080642  
(Assembled on Upper Mount)

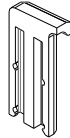

(1) Nylon Cap  
Passenger Side  
Part #080643  
(Assembled on Upper Mount)

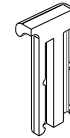

**PARTS BAG # 771315**

a) (6) Capscrew  
1/4"-20 x 5/8" SS, oxidized  
Part #014071



b) (4) Screw, Sheet Metal, Blk Ox.  
1/4" Hex Washer Head, #8-18x1"  
Part # 016055



c) (4) Spacer Washer, HDPE  
5/16" x 1" x 1/4"  
Part # 018036



d) (6) Washer, Flat  
0.281" x 1", SS, ox.  
Part #018069

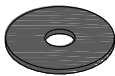

e) (4) Washer, Offset  
0.203" x 1" SS Ox.  
Part #018070



f) (2) Washer, Nylon  
0.281" x 1"  
Part #054084



g) (4) Spacer Washer, HDPE  
7/16" x 1" x 1/4"  
Part #054091



h) (2) Universal U-clamp  
1.5" x 4" Blk Anodized  
Part #766960

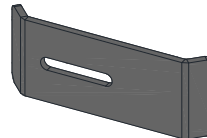

i) (3) Mud Flap Clip  
Driver Side  
Part # 769312

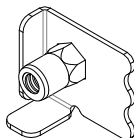

j) (3) Mud Flap Clip  
Passenger Side  
Part #769313

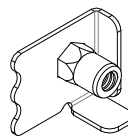



## MUD FLAPS:

Before you install your Mud Flap Set, see the parts list for all necessary parts. Start on the driver's side.

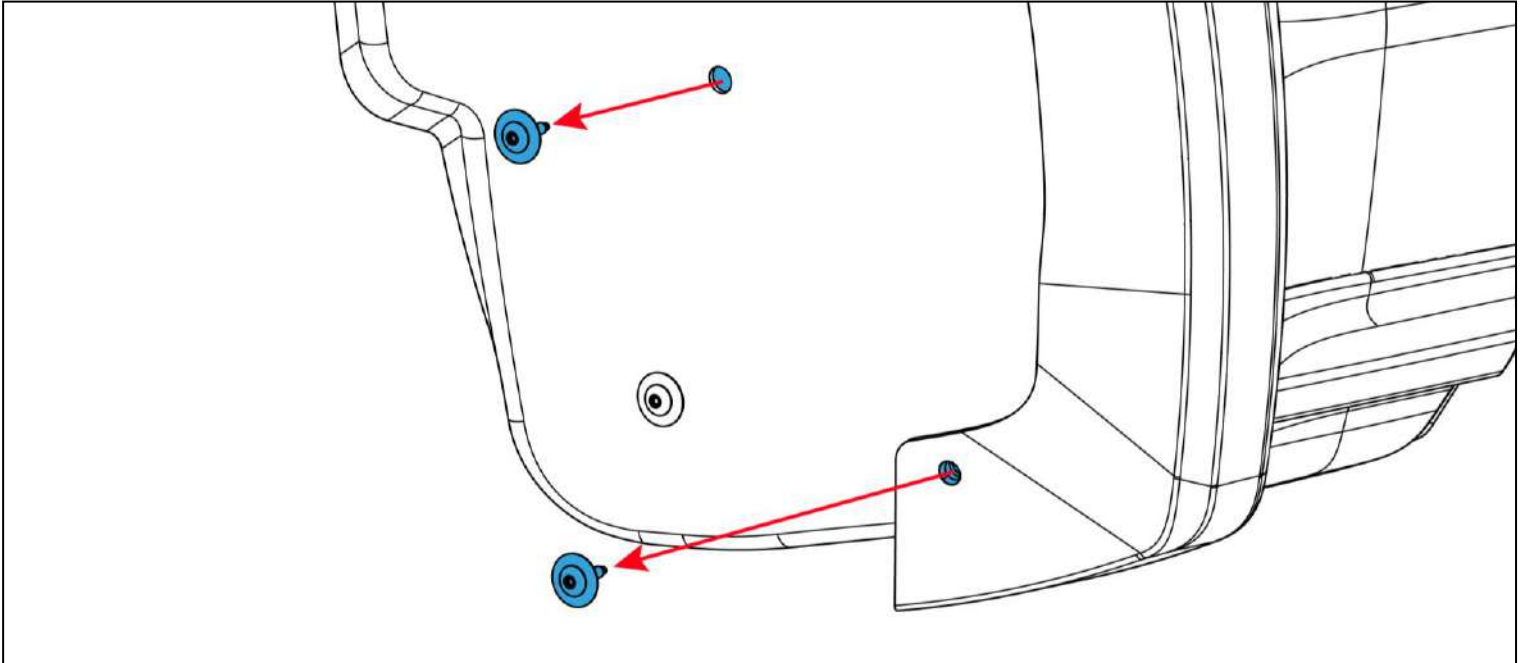

1-1 Remove the 2 factory screws from the wheel well as shown. (outermost and upper innermost)

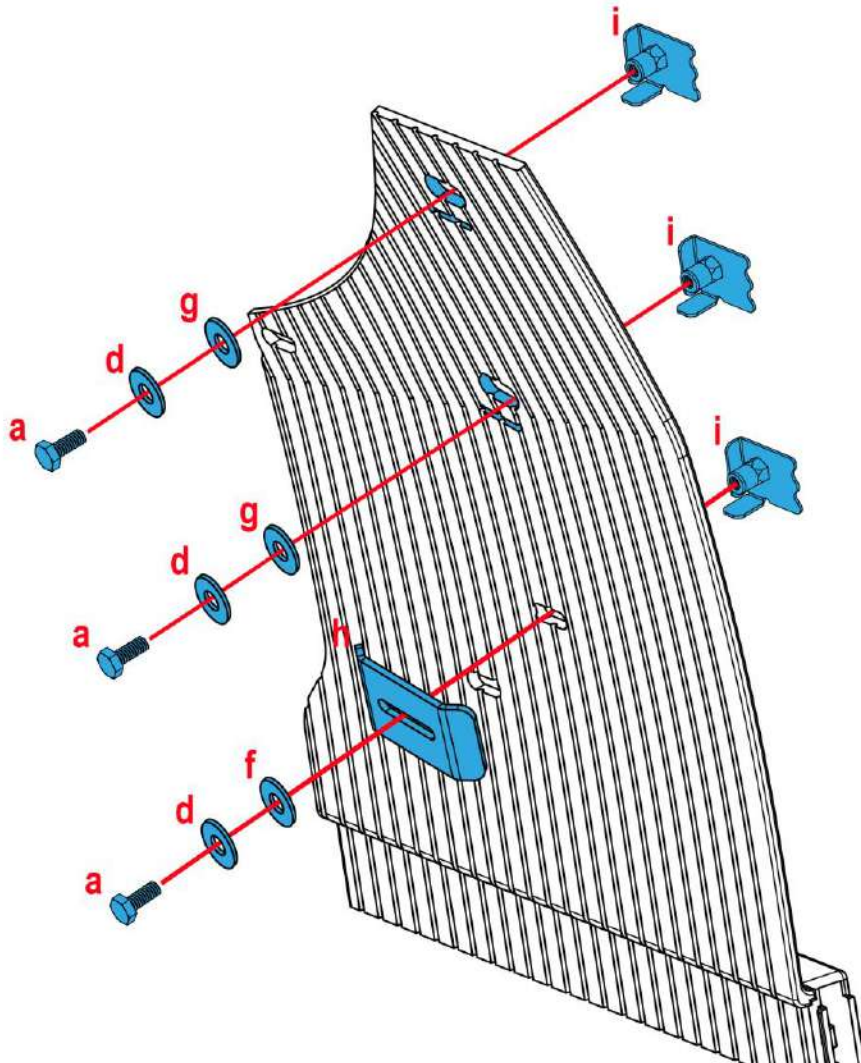

2-1 Loosely install mount clips (i) on mud flap holes 1 to 3 as shown.

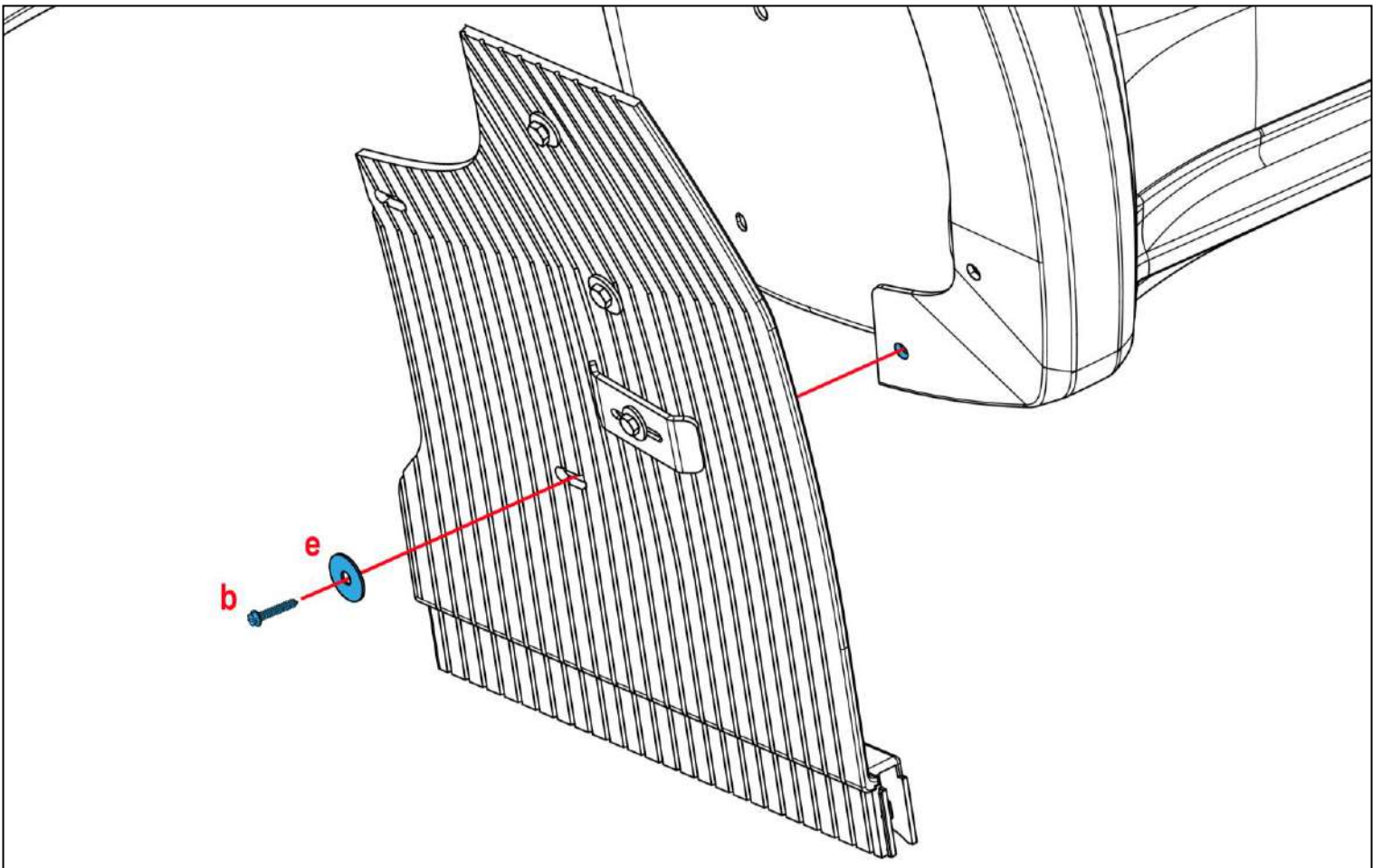

3-1 Install mud flap hole #4 to factory hole as shown.

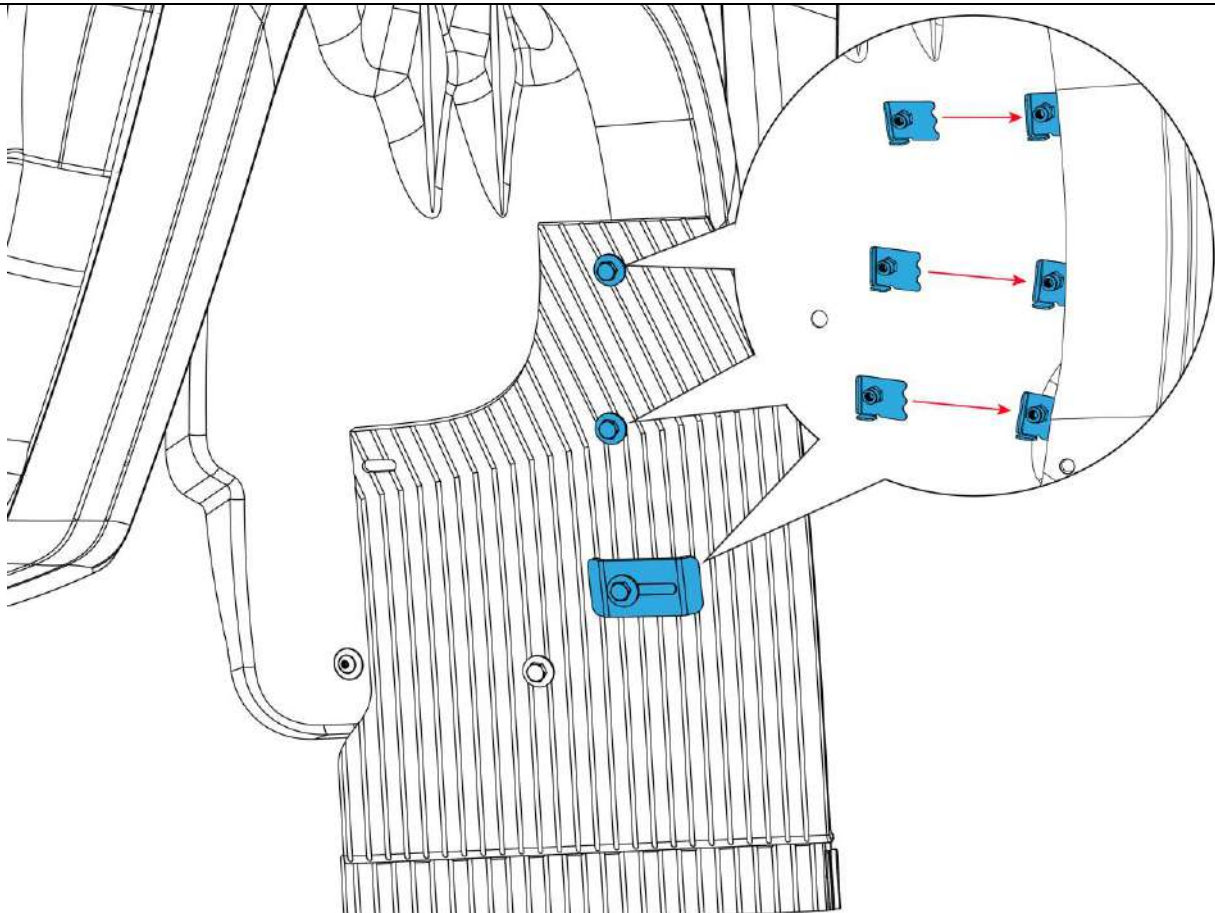

4-1 Slide mount clips behind the fender lip and loosely secure.

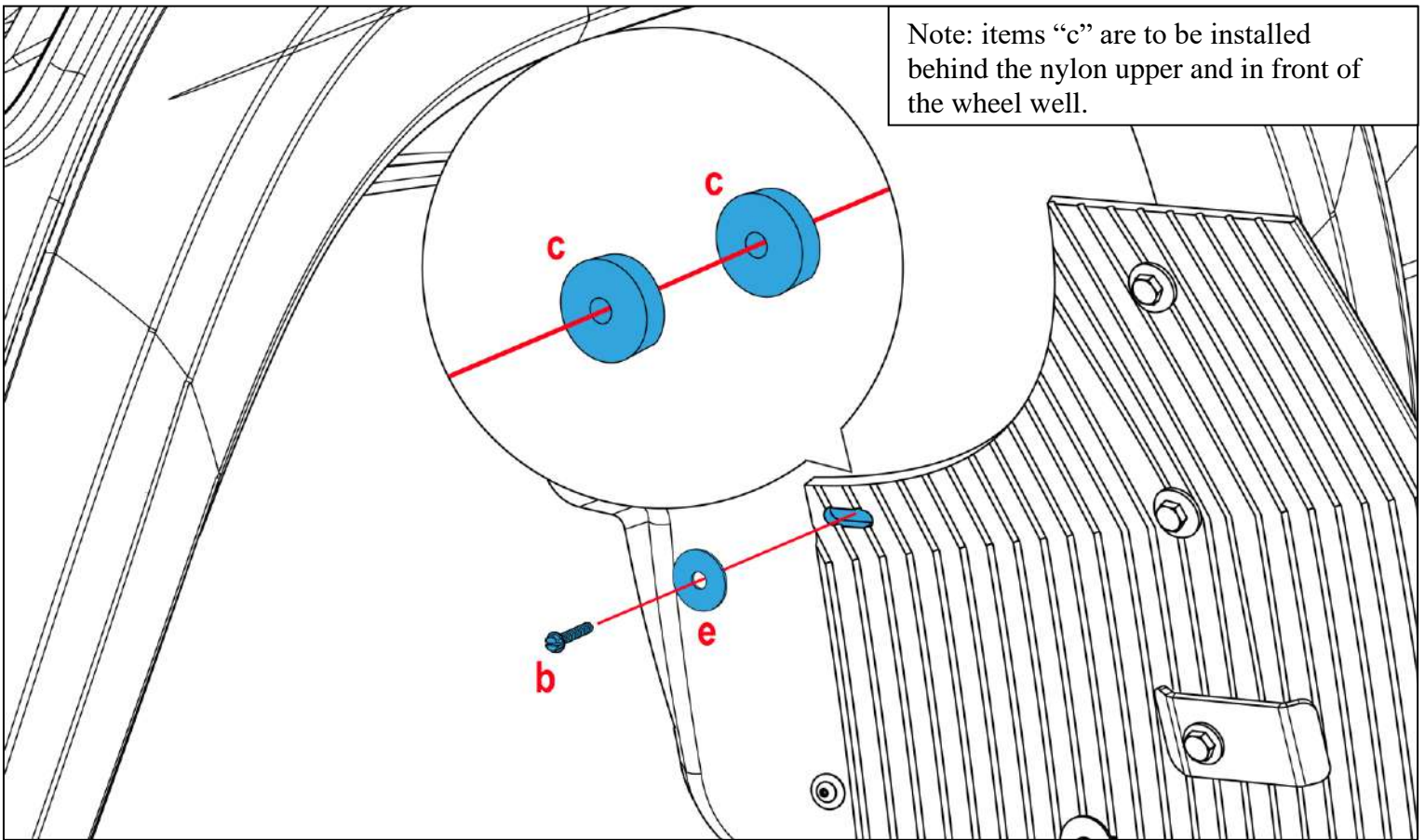

5-1 Install mud flap hole #5 to factory hole using (b) and (e), placing (c) between the flap and fender as shown.

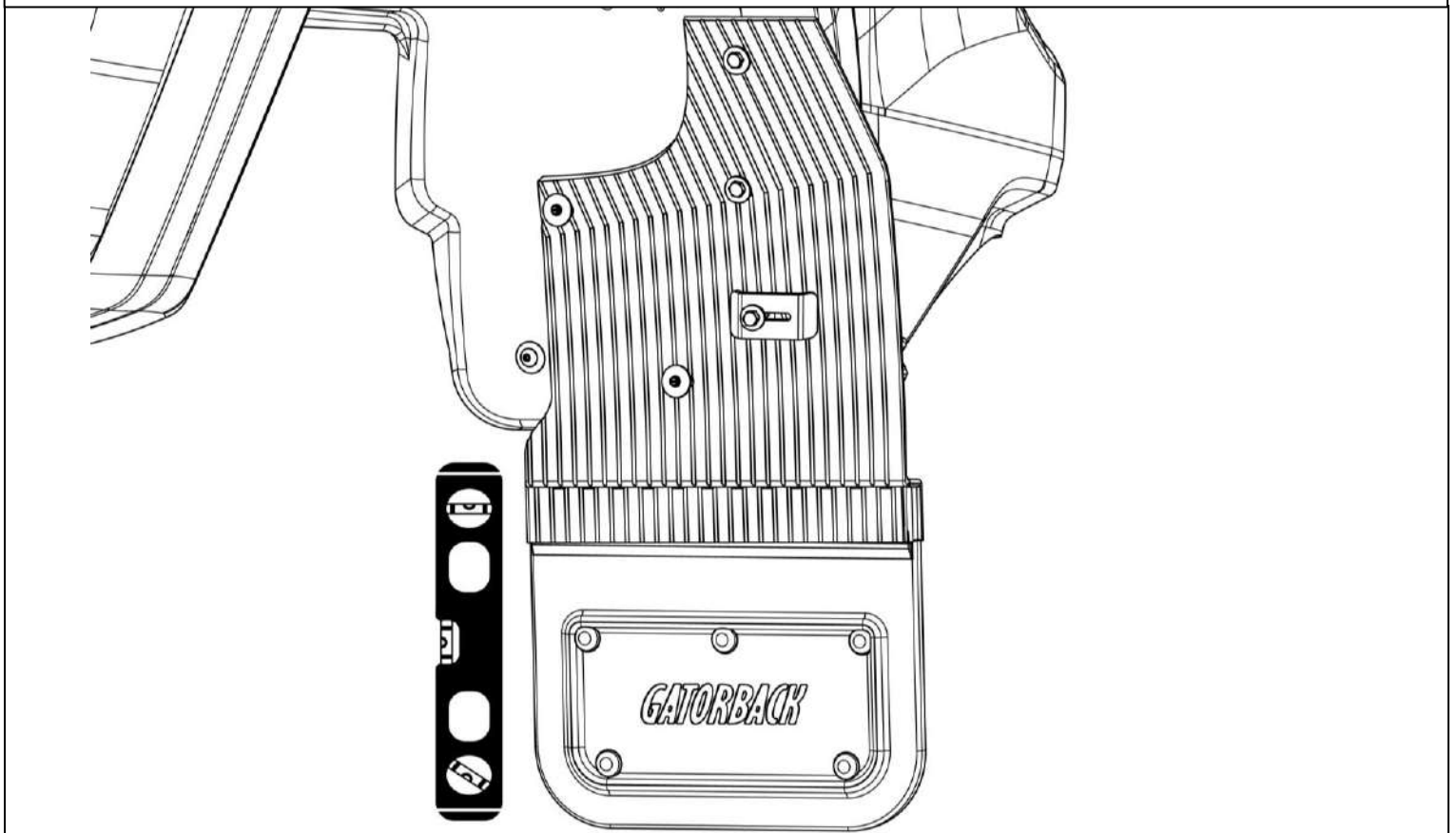

8-1 Using a bubble level or other levelling tool, ensure that the mud flap is level. Tighten fasteners. Be sure to align the u-clamps so they are adding pressure to hold the mud flap tight against the wheel well.

Repeat procedure for passenger side.

## ASSEMBLY OF NYLON MUD FLAPS:

1. Remove locking caps from nylon upper mounts and set aside for reinstallation.
2. Remove and discard the plastic strip inside the track at the bottom of the nylon upper mount.
3. Slide rubber guide into track of nylon upper mount.
4. Reinstall locking cap(s) on bottom of nylon upper mount. **Note: To fully lock this cap into place, you should hear two clicks.** When the cap is fully locked, it will be even with the offset part of the upper mount.
5. Repeat Procedure for second mud flap.

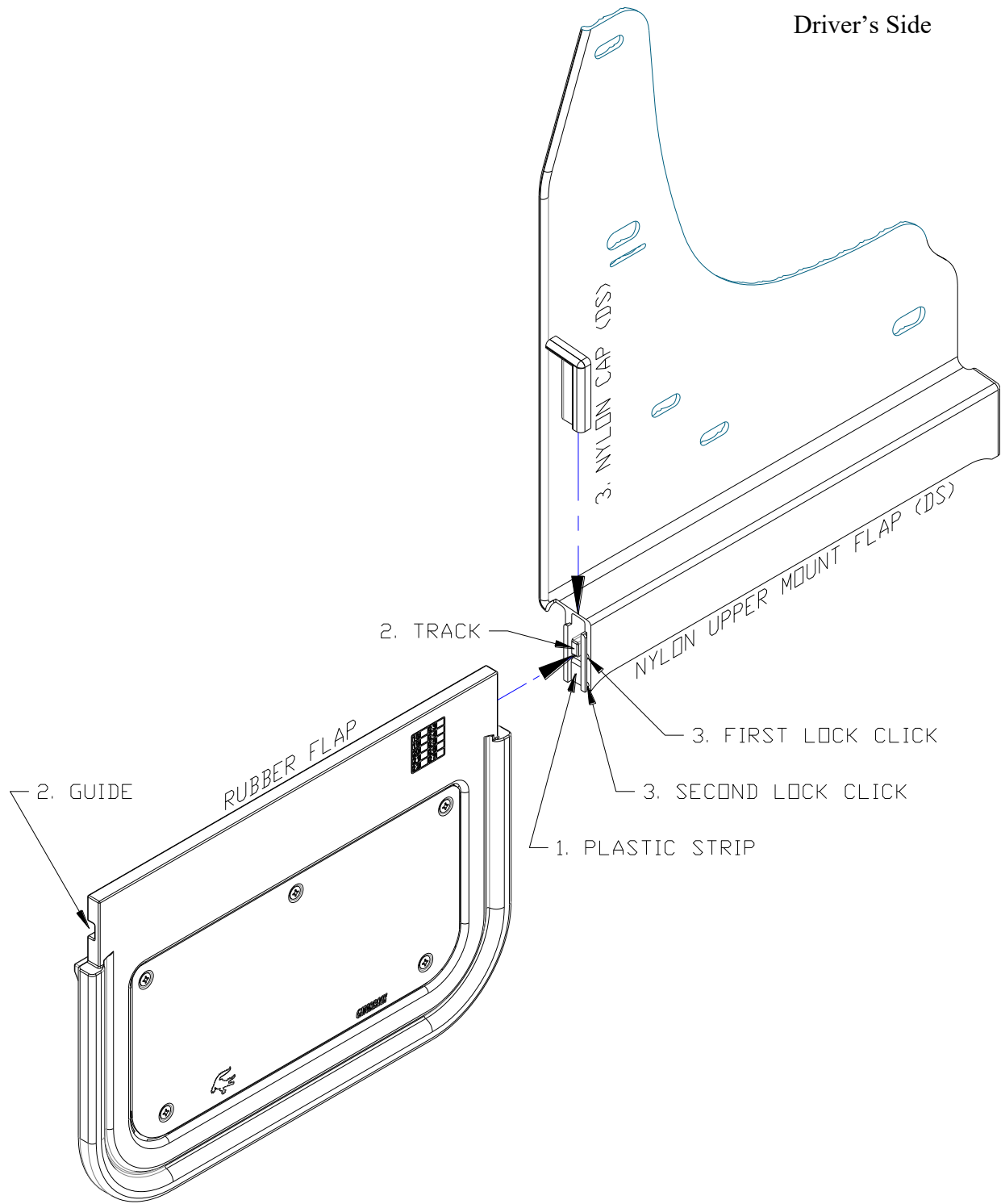

Please check out our YouTube channel to see an install video for this application.

